

*Goodwin*

**100 mm SDSS 30kW 50Hz**  
**ACID RESISTANT**  
**SUBMERSIBLE SLURRY PUMP**

NUMBER ONE FOR RELIABILITY, STRENGTH & ENDURANCE

**TECHNICAL DATA SHEET**

# 100 mm SDSS **30kW 50Hz** SUBMERSIBLE SLURRY PUMP

Goodwin submersible pumps have been manufactured since 1982 and are recognised as market leaders in terms of performance and reliability. The pumps have been continually developed over 4 decades resulting in machines that can perform in the most demanding environments.

## Standard Engineering Features

- Single piece motor housing to enhance rigidity and reduce wear
- 3 phase electric motor runs in oil bath to lubricate and cool the motor parts
- Cooling assisted by the pumped fluid passing through the pump body
- Twin volute casing design to reduce rotational imbalance and increase lifetime of bearings and seals
- Rotating inducer creates hydrodynamic shock waves to re-suspend settled particles beneath the pump inlet
- Carefully chosen corrosion resistant materials to maximise service lifetime
- Single stage, open vane impeller
- Precision bearings
- Non pressurised mechanical seal

## Applications

- Mine tailings recovery and reprocessing
- Minerals processing - separation, purification, concentration
- Acid tank and lagoon cleaning
- Salt water applications

## Pump Performance

Design fluid handled	Slurry
Maximum fluid SG	2.8 kg/l
Maximum fluid solids content	65 % by weight
Maximum particle size	32 mm
Maximum fluid temperature	90 °C
Recommended pH range	0-14
Power	30 kW
Speed	1450 rpm
Weight	770 kg
Outlet Diameter	100 mm
Maximum Flow	220 m <sup>3</sup> /hr
Maximum Head	38 m (3.7 bar)
Impeller diameter	320 mm
Impeller tip speed	24 m/s
Peak efficiency	62 %
Maximum submergence depth*	28 m
Shut off head at maximum pump speed	38 m

\* as standard, can be deeper if required

## Electrical Data

Motor Type	Squirrel-cage induction motor
Frequency	50Hz
Phase	3
Motor rating	IEC 60034-1
IP protection rating	IP68
Starting method	Direct on-line, Soft Start, Variable Speed Drive. Note: Star Delta not available
Number of starts per hour	20
Voltage variation	± 6%
Voltage imbalance between phases	Max 2%
Insulation Code	H (180°C)
Motor Overload Factor	1.66
Duty Rating	S1
Efficiency Class	IE exempt (integral with pump)
Oil Type	Mineral uninhibited to IEC 60269 (04)
Standards complied with	IEEE 112-2004, IEC 60034-1-2, AS60034-1, JEC 37
Noise level at 1m when not submerged	78 dB
Motor efficiency	88%

# Goodwin



## Electrical Data

Voltage	Rated power (kW)	RPM	Rated (full load) Current (A)	Inrush Current Direct on Line (A)	No Load Current (A)	Power Factor cos $\phi$ (full load)	Power Factor cos $\phi$ (75% load)	Power Factor cos $\phi$ (50% load)	Recommended Over Current Protection (A)
380	30	1450	58	300	14	0.91	0.82	0.81	100
415	30	1450	54	280	13	0.91	0.82	0.81	100
525	30	1450	42	220	10	0.91	0.82	0.81	100
660	30	1450	33	170	8	0.91	0.82	0.81	80
1000	30	1450	22	120	6	0.91	0.82	0.81	50

## Materials

	Material	Pitting Resistance (PREn)
Pump Body	Super Duplex Stainless Steel	>40
Fasteners		
Pump Shaft		
Impeller	Cr, Mo, Co alloy with acid resistance and high hardness	Not applicable for this alloy
Inducer		
Wear Plate		
Cable	Fluorethylene propylene FEP	Both chemically and heat resistant
Elastomeric Seals	FEP Encapsulated Viton	Both chemically and heat resistant
Mechanical Seal	Fully Sintered Silicon Carbide	Both chemically and heat resistant
Other	Inconel 625	>45
Other	PTFE	Chemically Inert

## Other Data

Recommended Cable	Chemical resistant 16mm <sup>2</sup> 3 phase + earth copper cored cable with black fluorethylene propylene (FEP) sheathing and FEP conductor insulation. Voltage rating 450/750V. Outer sheath is flame resistant to IEC 60332-3 Cat A. External diameter 20.5 ± 1mm. Weight 1kg/m.	
Recommended Lifting Chains	Length 0.6m.	Material: super duplex stainless steel SWL 1500kg
Hose Outlet	Configuration	100mm PN10 M16*2.0P 8 places Ø180mm PCD
Cable Gland	Material	Super Duplex Stainless Steel
	Specification	BS6121:Part 1:1989
Control Panel	Rating	IP65
	Weight	65Kg
	Description	Voltage protection, earth leakage protection, phase imbalance, automatic operation with level switch and timer. DOL standard, soft start or VSD optional

# 100 mm SDSS 30kW 50Hz SUBMERSIBLE SLURRY PUMP

## Weights & Dimensions

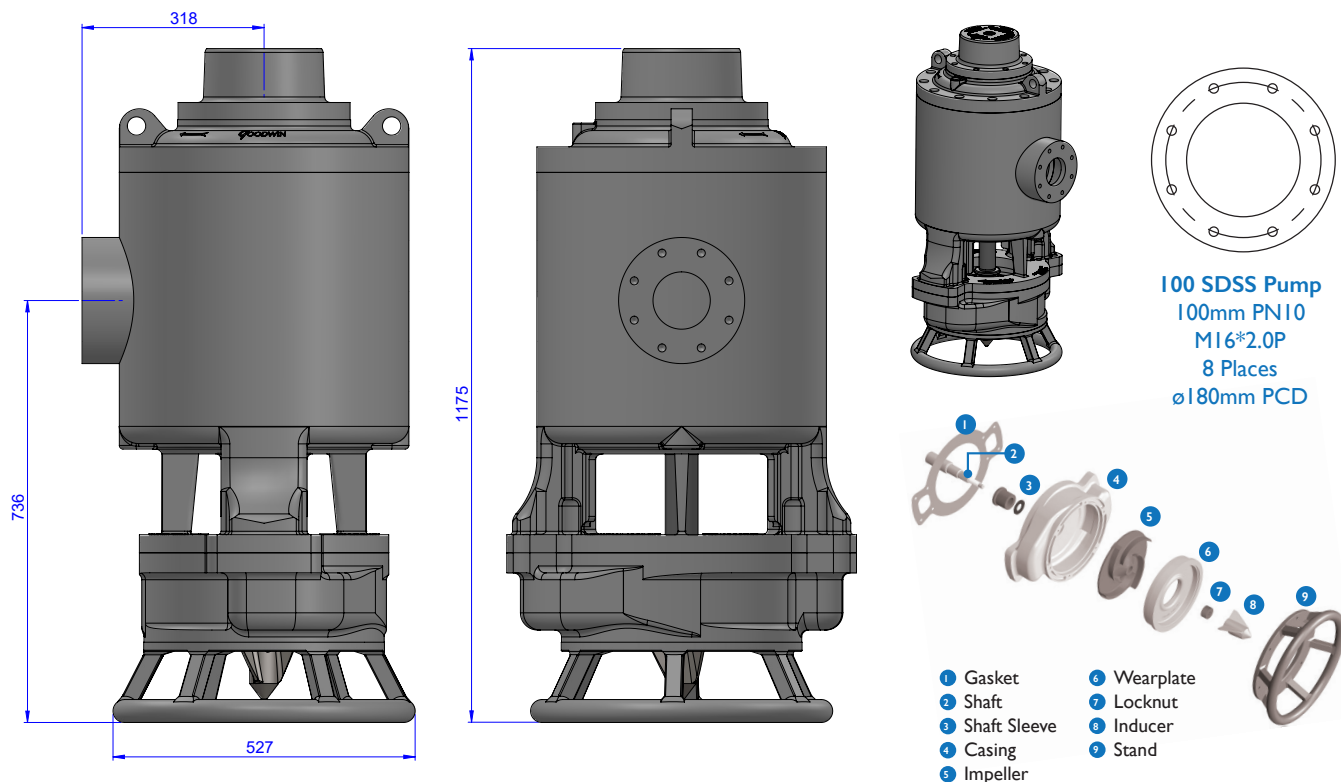

## Pump Curve

